

- GENERAL NOTES:**
1. Contractor and Subcontractor shall verify all dimensions of the drawing and site conditions prior to any work commencing.
 2. All Shop Drawings shall be submitted to the Project Architect. The Manufacturer shall not commence any works prior to the return of the approved Shop Drawings signed by the relevant consultant.
 3. Figured dimensions take precedence over scaled dimensions. DO NOT SCALE from drawings. Architectural Hardware Consulting Pty Ltd cannot guarantee the accuracy of content and format for copies of drawings issued electronically.
 4. This drawing should be read in conjunction with all relevant contracts, specifications and drawings.
 5. Copyright of this drawing is vested in Architectural Hardware Consulting Pty Ltd. The information contained in this document is copyright and may not be used or reproduced for any other project or purpose.
 6. For additional setout information where no dimensioning is shown, refer to reference tags for detailed drawings.

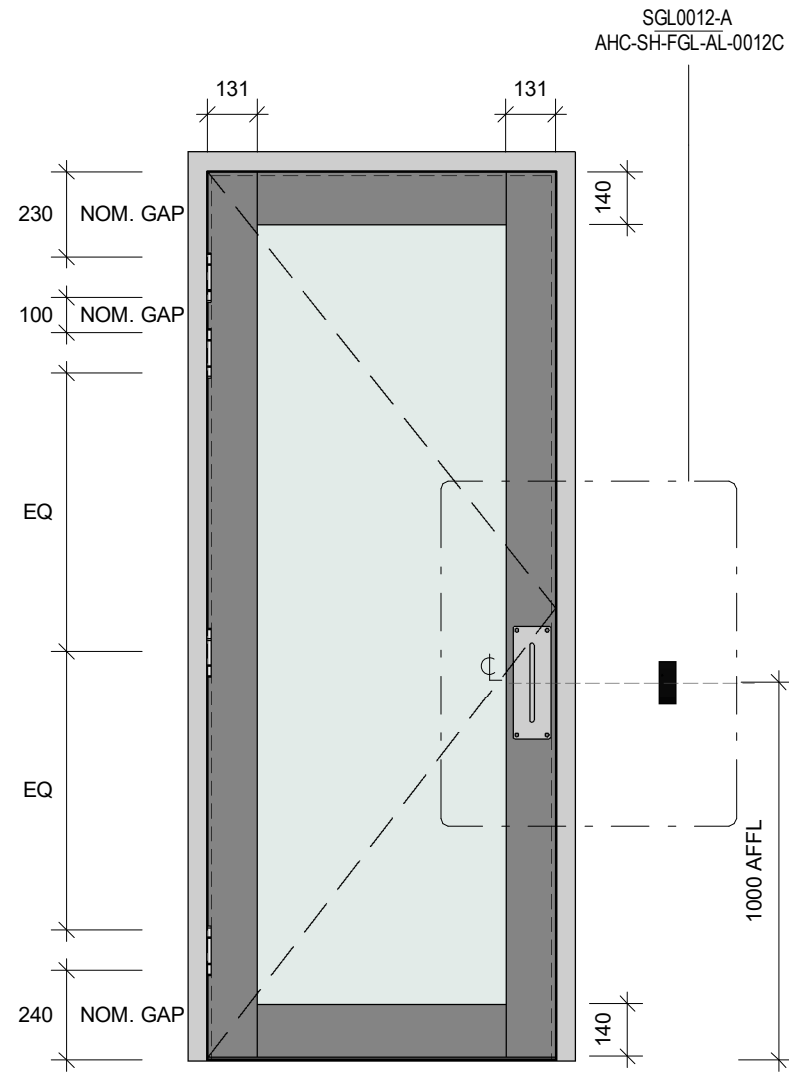

OUTSIDE ELEVATION
PULL SIDE

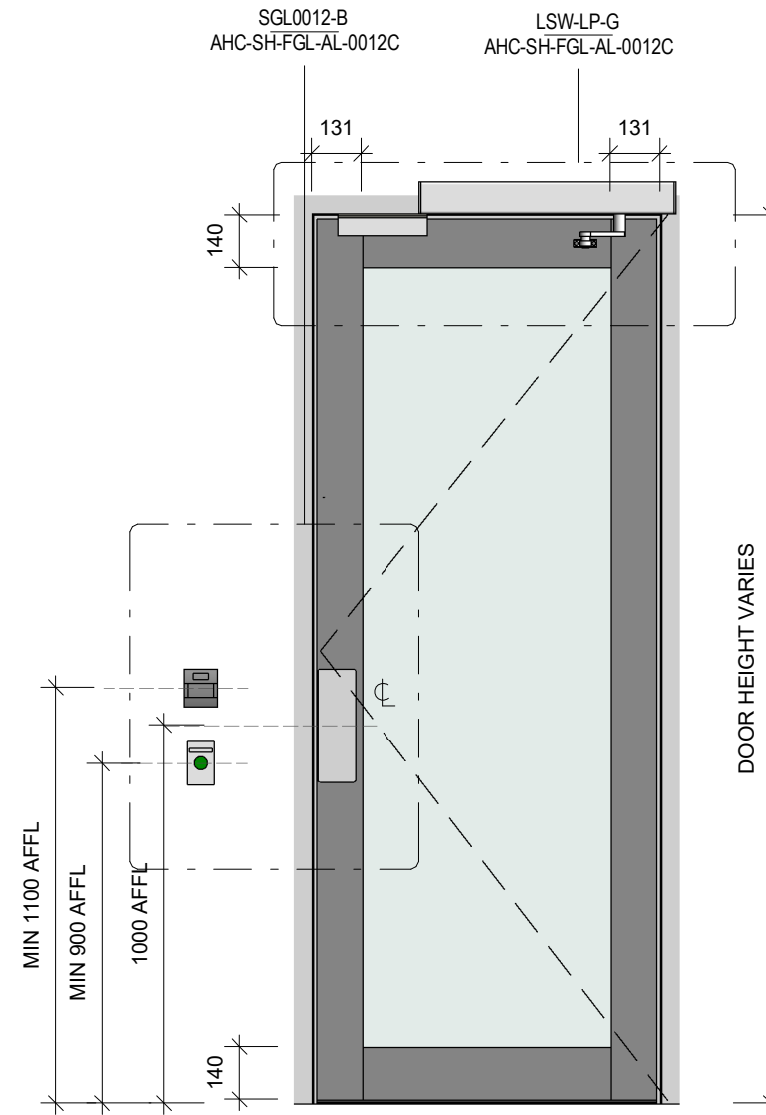

INSIDE ELEVATION
PUSH SIDE

PROJECT TITLE
-

DRAWING TITLE
**SINGLE, HINGED, SOLID
CORE DOOR**

DWG No:
LSW-LP B - 0012A

DATE: 06/06/20	REV
DRAWN BY: DR	

- GENERAL NOTES:**
1. Contractor and Subcontractor shall verify all dimensions of the drawing and site conditions prior to any work commencing.
 2. All Shop Drawings shall be submitted to the Project Architect. The Manufacturer shall not commence any works prior to the return of the approved Shop Drawings signed by the relevant consultant.
 3. Figured dimensions take precedence over scaled dimensions. DO NOT SCALE from drawings. Architectural Hardware Consulting Pty Ltd cannot guarantee the accuracy of content and format for copies of drawings issued electronically.
 4. This drawing should be read in conjunction with all relevant contracts, specifications and drawings.
 5. Copyright of this drawing is vested in Architectural Hardware Consulting Pty Ltd. The information contained in this document is copyright and may not be used or reproduced for any other project or purpose.
 6. For additional setout information where no dimensioning is shown, refer to reference tags for detailed drawings.

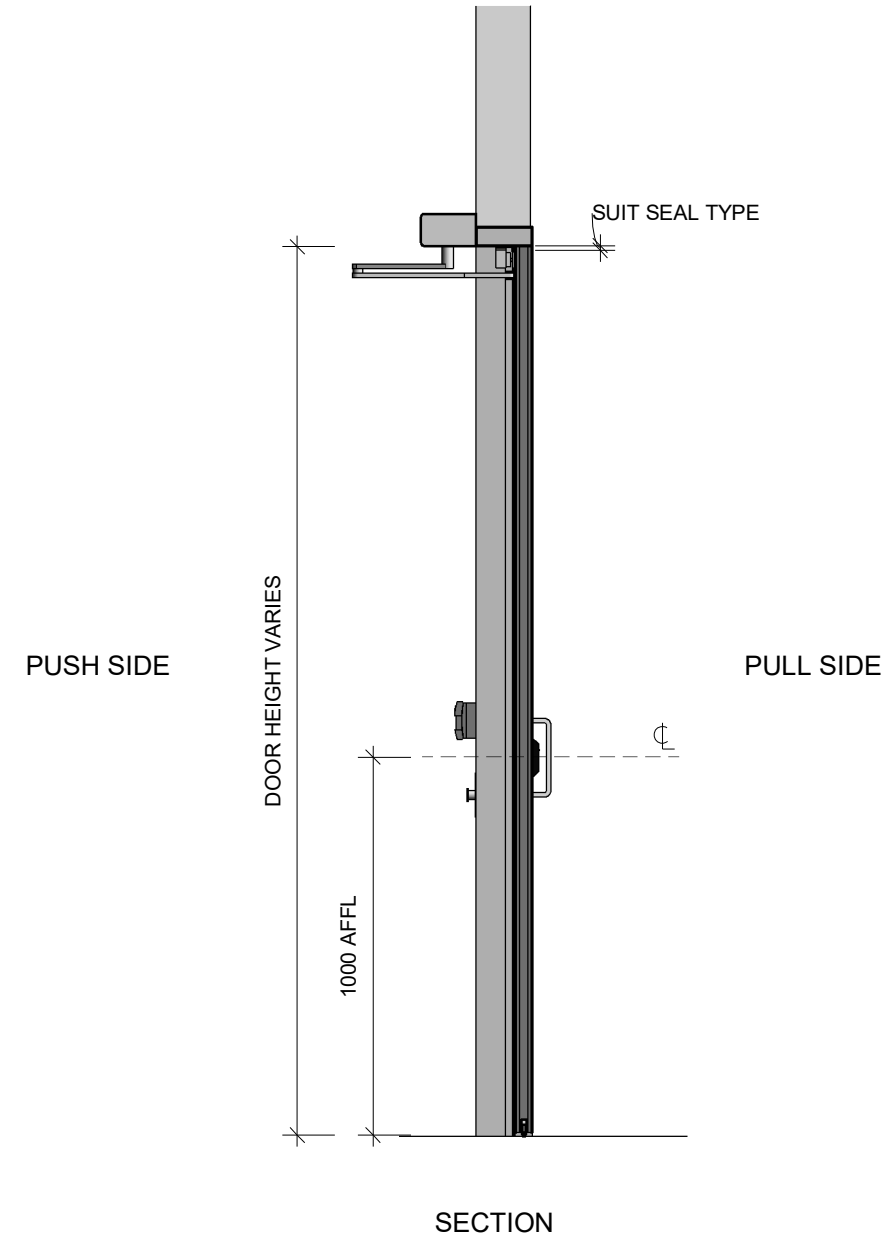
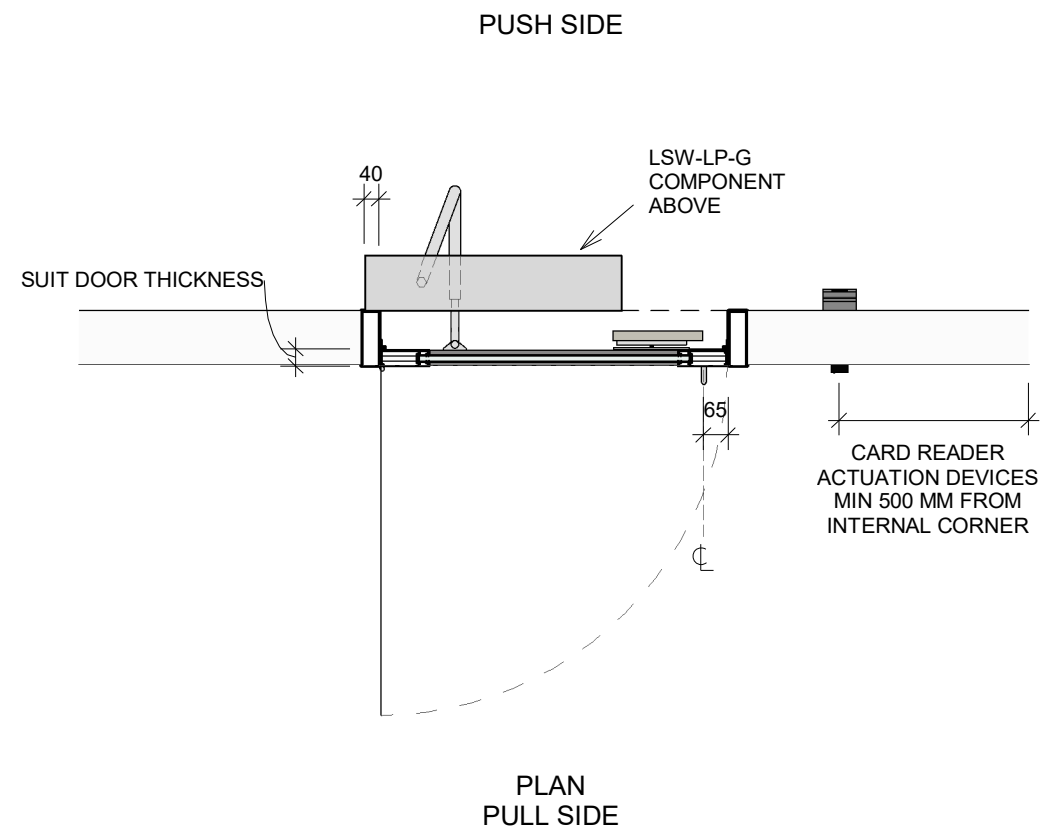

PROJECT TITLE	
-	
DRAWING TITLE	
SINGLE, HINGED, SOLID CORE DOOR	
DWG No:	
LSW-LP B - 0012B	
DATE:	REV
06/06/20	
DRAWN BY:	
DR	

NOTE:
USE PACKERS TO
CLEAR JAMB STOP
SEAL

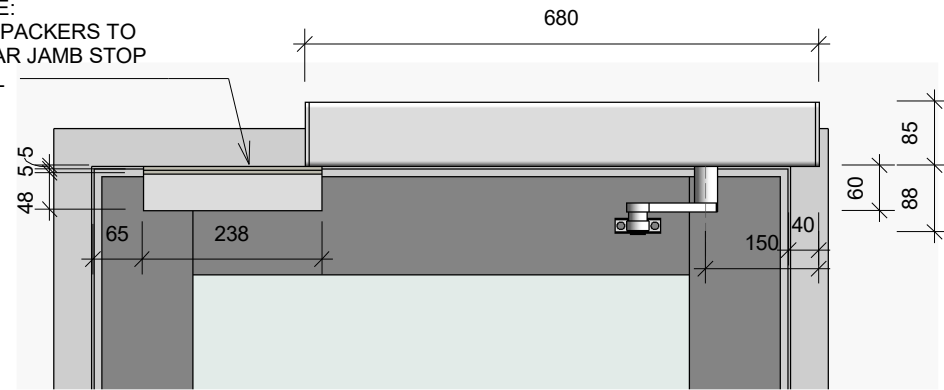

LSW-LP-G & L24
PUSH SIDE

NOTE:
USE PACKERS TO
CLEAR JAMB STOP
SEAL

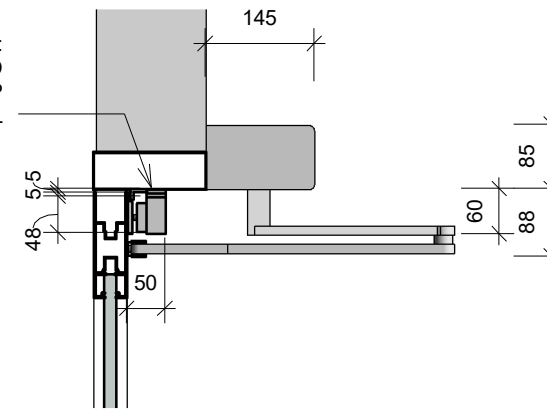

LSW-LP-G
& L24

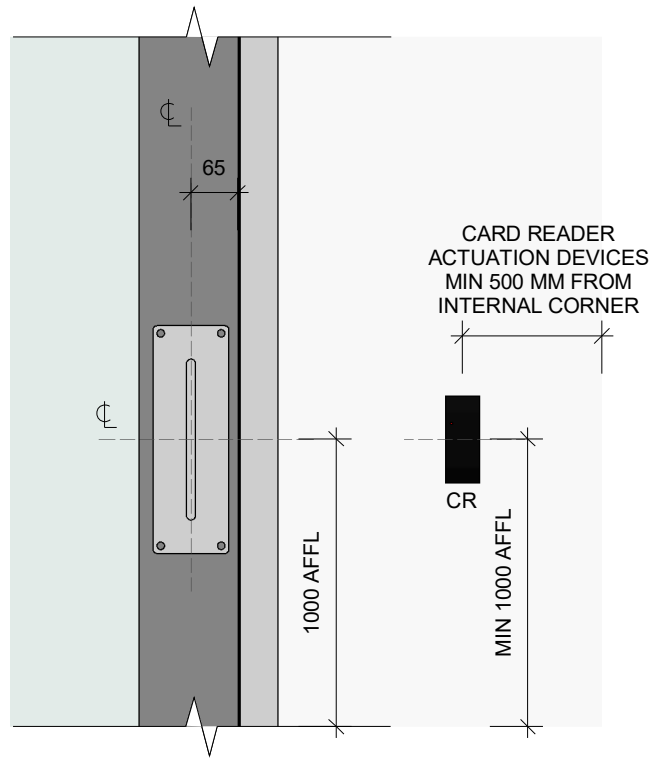

SGL0012-A
PULL SIDE

BREAK GLASS AND
EMERGENCY EXIT BUTTON
MIN 500 MM FROM
INTERNAL CORNER

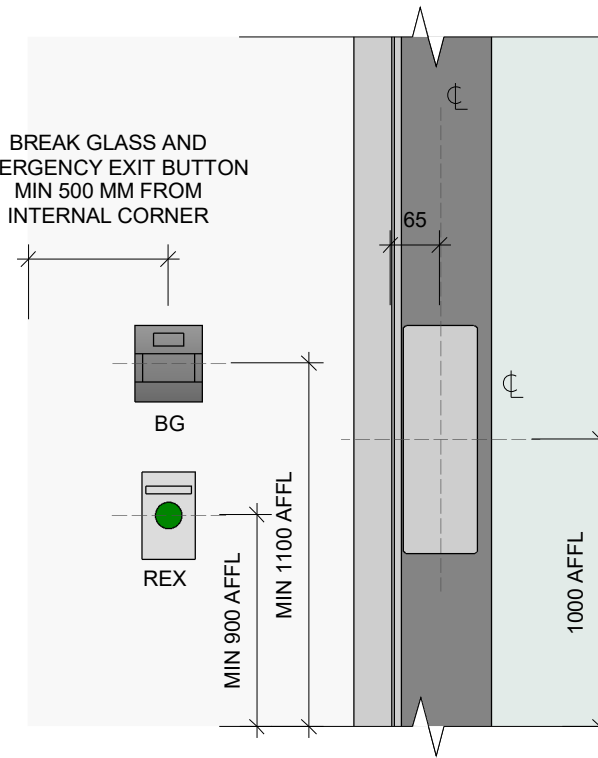

SGL0012-B
PUSH SIDE

GENERAL NOTES:

1. Contractor and Subcontractor shall verify all dimensions of the drawing and site conditions prior to any work commencing.
2. All Shop Drawings shall be submitted to the Project Architect. The Manufacturer shall not commence any works prior to the return of the approved Shop Drawings signed by the relevant consultant.
3. Figured dimensions take precedence over scaled dimensions. DO NOT SCALE from drawings. Architectural Hardware Consulting Pty Ltd cannot guarantee the accuracy of content and format for copies of drawings issued electronically.
4. This drawing should be read in conjunction with all relevant contracts, specifications and drawings.
5. Copyright of this drawing is vested in Architectural Hardware Consulting Pty Ltd. The information contained in this document is copyright and may not be used or reproduced for any other project or purpose.
6. For additional setout information where no dimensioning is shown, refer to reference tags for detailed drawings.

PROJECT TITLE

DRAWING TITLE
FIT OFF DETAIL

DWG No:
LSW-LP B - 0012C

DATE: 06/06/20	REV
DRAWN BY: DR	

- GENERAL NOTES:**
1. Contractor and Subcontractor shall verify all dimensions of the drawing and site conditions prior to any work commencing.
 2. All Shop Drawings shall be submitted to the Project Architect. The Manufacturer shall not commence any works prior to the return of the approved Shop Drawings signed by the relevant consultant.
 3. Figured dimensions take precedence over scaled dimensions. DO NOT SCALE from drawings. Architectural Hardware Consulting Pty Ltd cannot guarantee the accuracy of content and format for copies of drawings issued electronically.
 4. This drawing should be read in conjunction with all relevant contracts, specifications and drawings.
 5. Copyright of this drawing is vested in Architectural Hardware Consulting Pty Ltd. The information contained in this document is copyright and may not be used or reproduced for any other project or purpose.
 6. For additional setout information where no dimensioning is shown, refer to reference tags for detailed drawings.

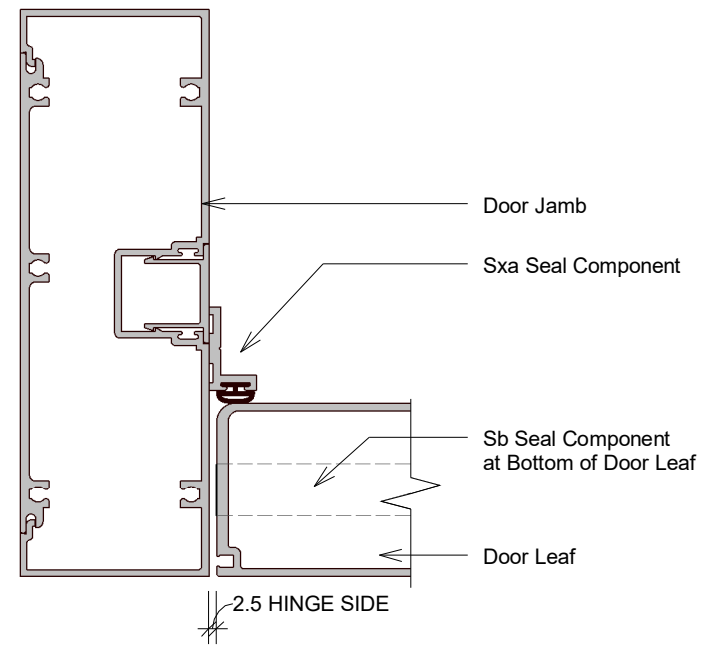

Sxa Seal

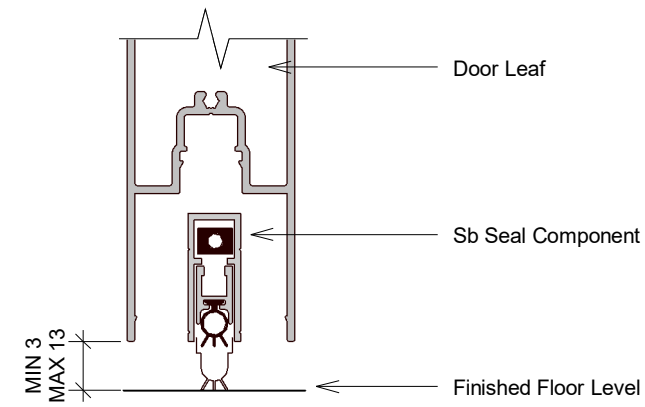

Sb Seal

NOTE: Refer to Manufacturer's Installations for Hollow Bottom Rail of Aluminium Hinged Door Applications

PROJECT TITLE

DRAWING TITLE
FIT OFF DETAIL

DWG No:
LSW-LP B - 0012D

DATE: 06/06/20	REV
DRAWN BY: DR	